

Powered By **ALLDATA** Information

ALLDATA[®]diy.com *Leading Source of Online Diagnostic & Repair Information!*

HELP	VEHICLE	ACCOUNT	EXIT
------	---------	---------	------

1990 Ford Truck Bronco Full Size V8-302 5.0L

- [Top - Vehicle](#)
- ↳ [Steering and Suspension](#)
- ↳ [Suspension](#)
- ↳ [Ball Joint](#)
- ↳ [Service and Repair](#)
- ↳ **Ball Joint, Upper**

SEARCH *or* **Contact ALLDATA**

[Notes](#)

Ball Joint, Upper

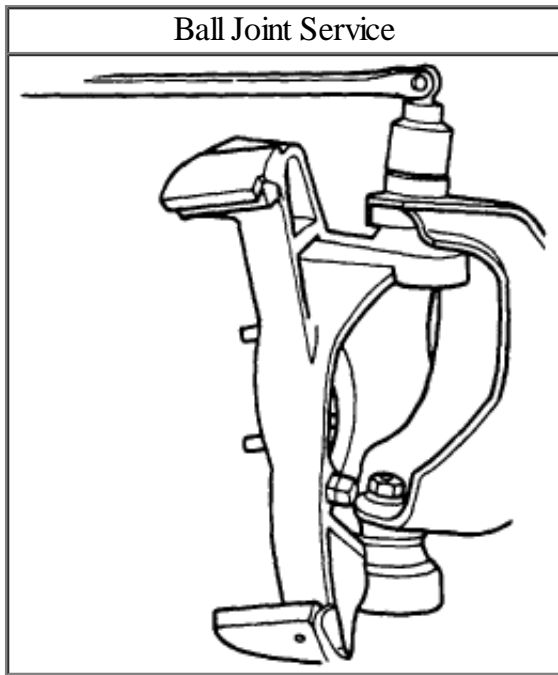

ZOOM SIZED FOR PRINT

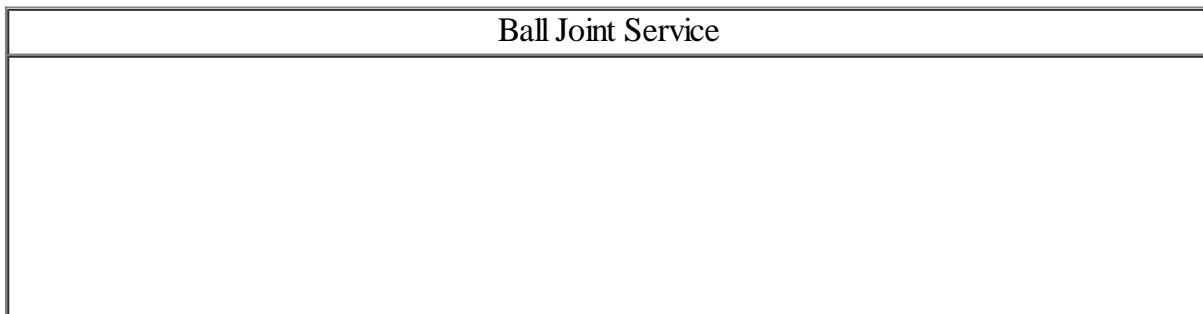

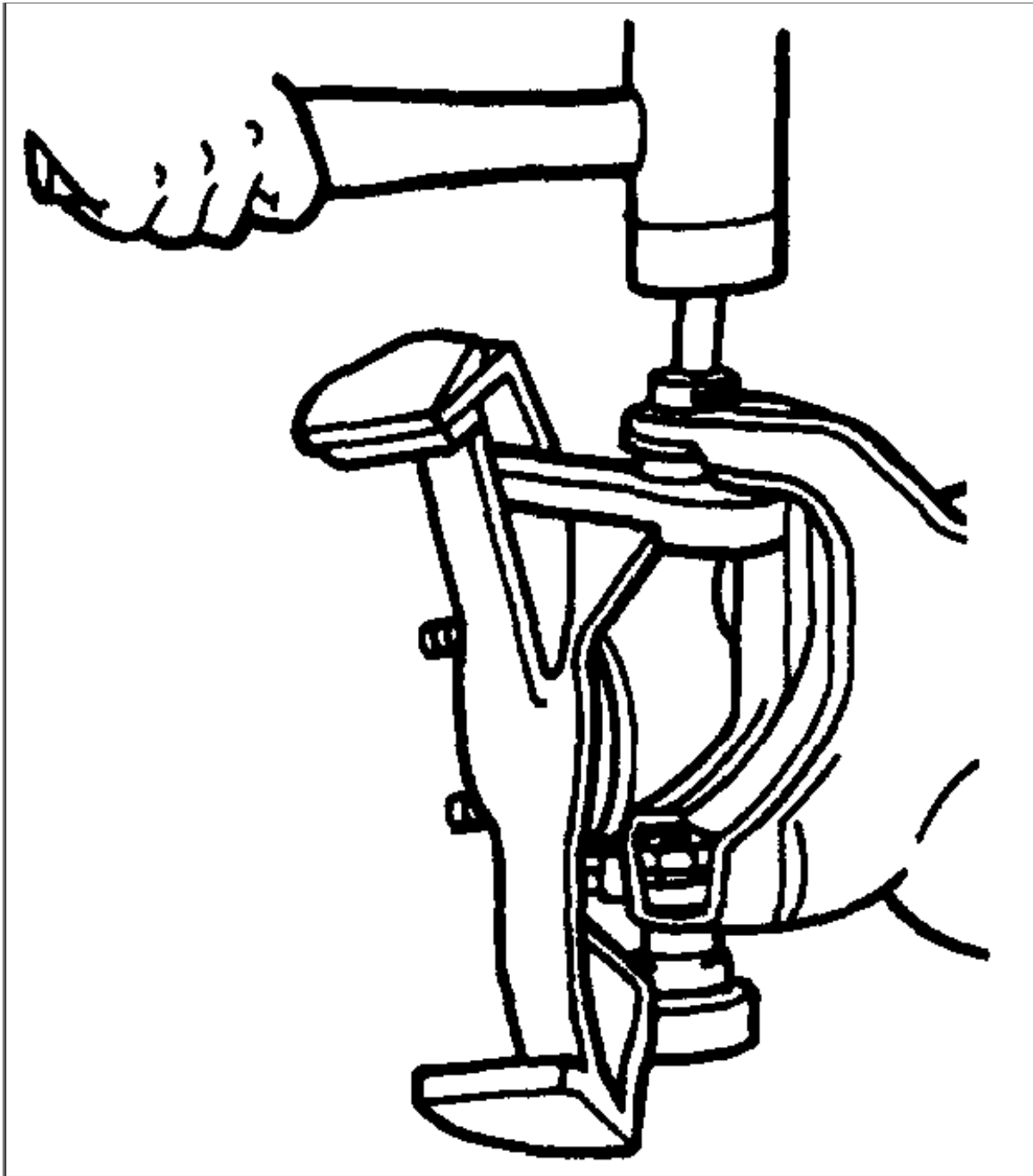

ZOOM

SIZED FOR PRINT

Ball Joint Service

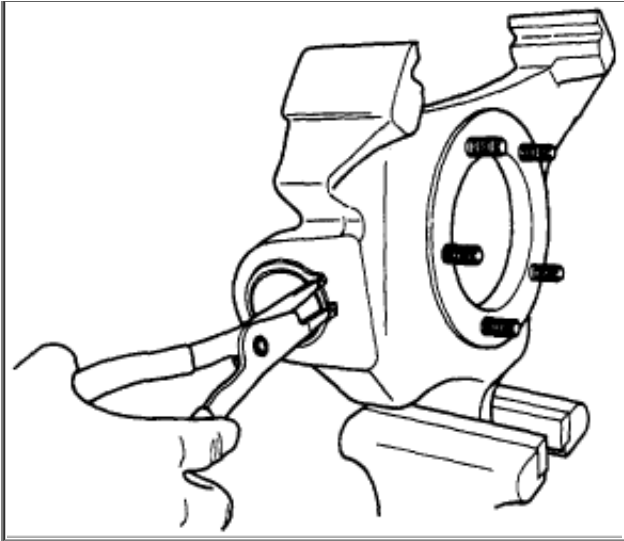

ZOOM

SIZED FOR PRINT

REMOVE

1. Remove brake rotor, axle shaft and [spindle](#) from [steering knuckle](#).
2. Disconnect the steering arm from the knuckle.
3. Remove upper ball joint nut and loosen lower ball joint nut. Using a rawhide or heavy duty plastic hammer, hit sharply on the top stud to free the knuckle from the tube yoke
4. Remove lower ball joint nut and remove knuckle from yoke tube.
5. Remove camber adjuster bushing from tube and yoke assembly.
6. Secure the knuckle in a vise. Remove the snap ring from the lower ball joint.

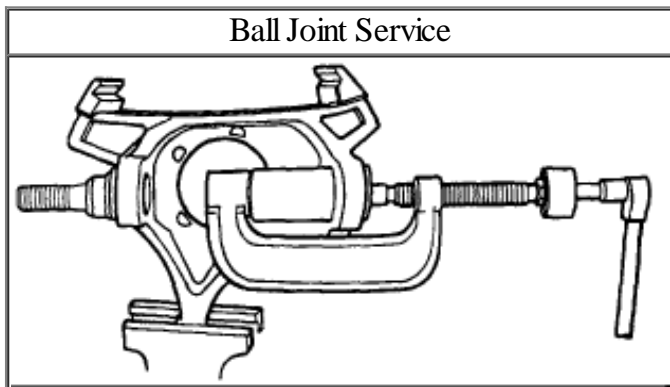

ZOOM

SIZED FOR PRINT

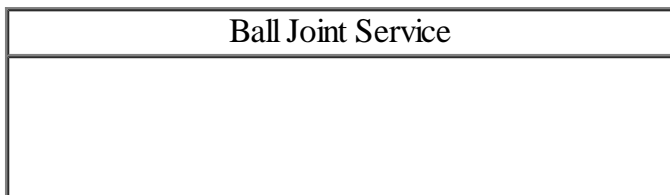

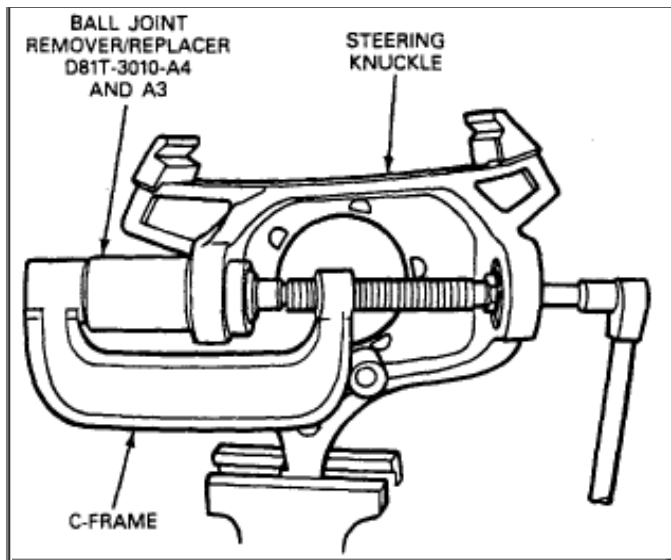

ZOOM

SIZED FOR PRINT

7. Assemble U-Joint Tool T74P-4635-C and Ball Joint Remover/Replacer T92T-3010-A over the lower ball joint. Turn the forcing screw to remove the ball joint.
8. Assemble U-Joint Tool T74P-4635-C, Ball Joint Remover/Replacer D81T-3010-A4 and Ball Joint Remover/Replacer D81T-3010-A3 or equivalents over the upper ball joint. Turn the forcing screw clockwise to remove the upper ball joint.

INSTALL

NOTE: The upper ball joint must be installed first.

1. Position the upper ball joint along with U-Joint Tool T74P-4635-C, Receiver Cup D81T-3010-A5, Ball Joint Remover/Replacer tools D81T-3010-A1, D81T-3010-A3 and D81T-3010-A4 or equivalents on the knuckle. Turn the forcing screw clockwise until the ball joint bottoms in the bore. Remove the tools.
2. Position the lower ball joint and U-Joint Tool T74P-4635-C, Ball Joint Remover/Replacer T92T-3010-B and Ball Joint Remover/Replacer T92T-3010-A on the knuckle. Turn the forcing screw clockwise until the ball joint bottoms in the bore. Remove the tools.
3. Install the snap ring on the lower ball joint.
4. Install knuckle onto tube and yoke assembly, then install camber adjusting bushing with arrow pointing outward for positive camber or towards center of vehicle for negative camber.
5. Install new lower ball joint nut and torque to **Specifications** . [See: Specifications\Ball Joint, Upper](#)
6. Install new upper ball joint nut and torque to **Specifications** . [See: Specifications\Ball Joint, Upper](#)
7. Advance upper ball joint nut to next castellation, and install new cotter pin.
8. Install brake rotor, axle shaft and [spindle](#).

12/30/2008

1990 Ford Truck Bronco Full Size V8...

Copyright © 2008 ALldata LLC

[Terms of Use](#)

Powered By **ALLDATA** Information

ALLDATA[®]diy.com *Leading Source of Online Diagnostic & Repair Information!*

HELP	VEHICLE	ACCOUNT	EXIT
------	---------	---------	------

1990 Ford Truck Bronco Full Size V8-302 5.0L

- [Top - Vehicle](#)
- ↳ [Steering and Suspension](#)
- ↳ [Suspension](#)
- ↳ [Ball Joint](#)
- ↳ [Service and Repair](#)
- ↳ **Ball Joint, Lower**

SEARCH or **Contact ALLDATA**

[Notes](#)

Ball Joint, Lower

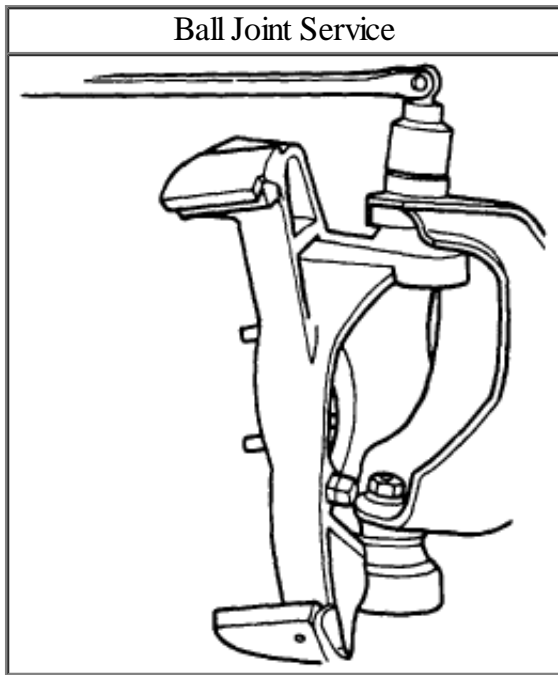

ZOOM SIZED FOR PRINT

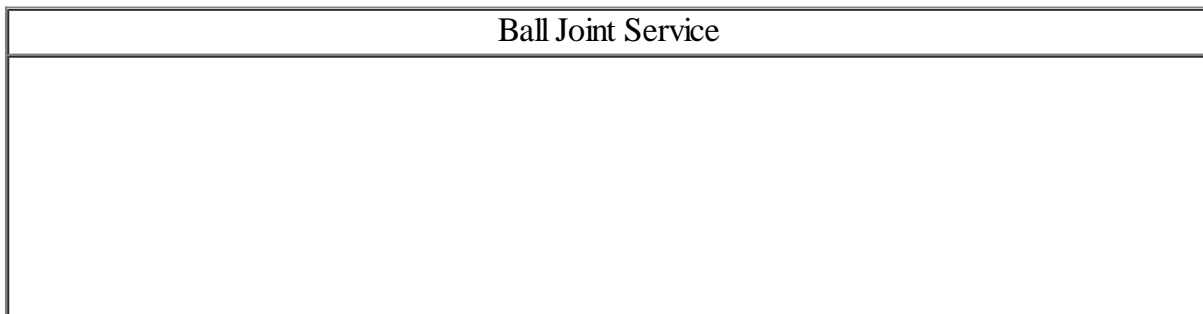

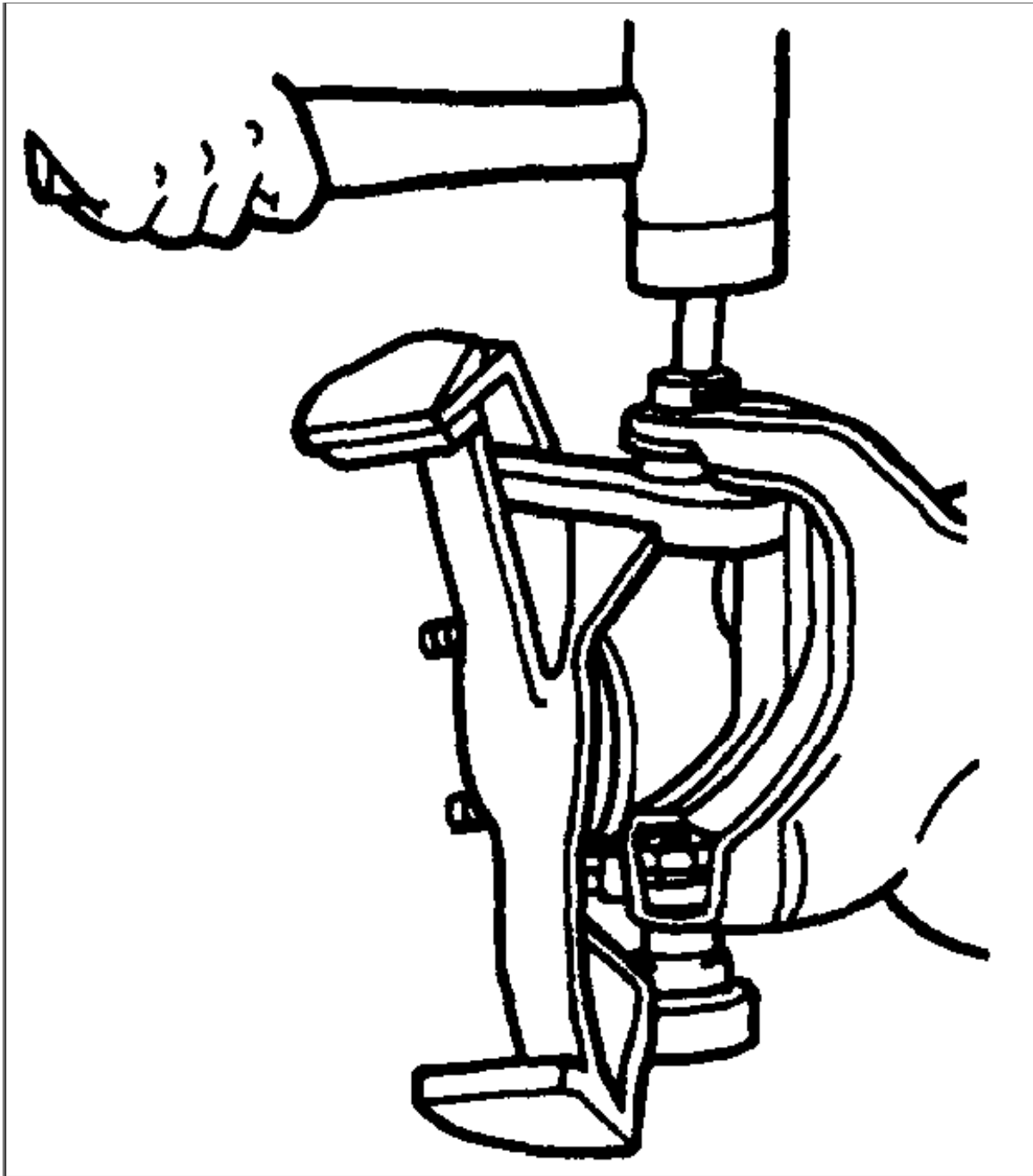

ZOOM

SIZED FOR PRINT

Ball Joint Service

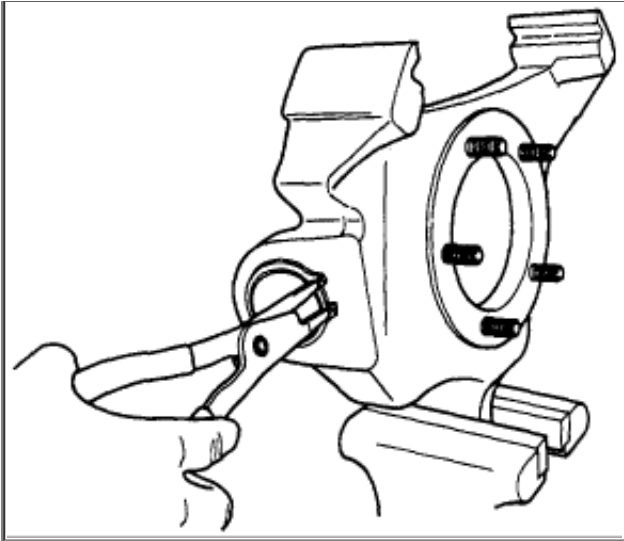

ZOOM

SIZED FOR PRINT

REMOVE

1. Remove brake rotor, axle shaft and [spindle](#) from [steering knuckle](#).
2. Disconnect the steering arm from the knuckle.
3. Remove upper ball joint nut and loosen lower ball joint nut. Using a rawhide or heavy duty plastic hammer, hit sharply on the top stud to free the knuckle from the tube yoke
4. Remove lower ball joint nut and remove knuckle from yoke tube.
5. Remove camber adjuster bushing from tube and yoke assembly.
6. Secure the knuckle in a vise. Remove the snap ring from the lower ball joint.

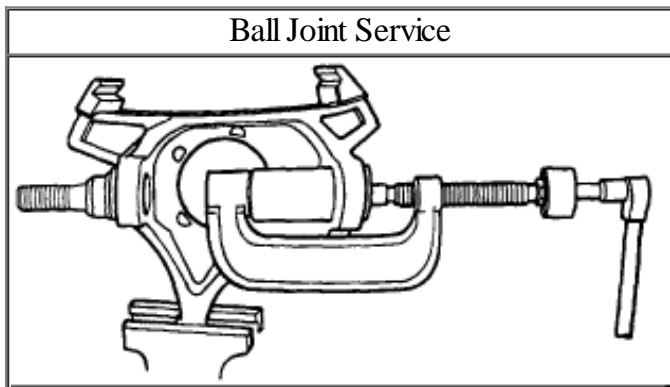

ZOOM

SIZED FOR PRINT

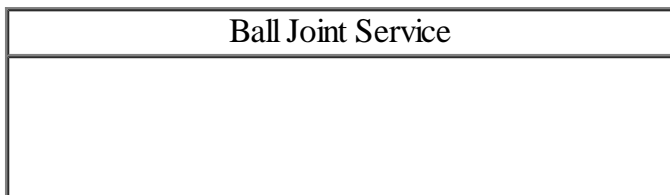

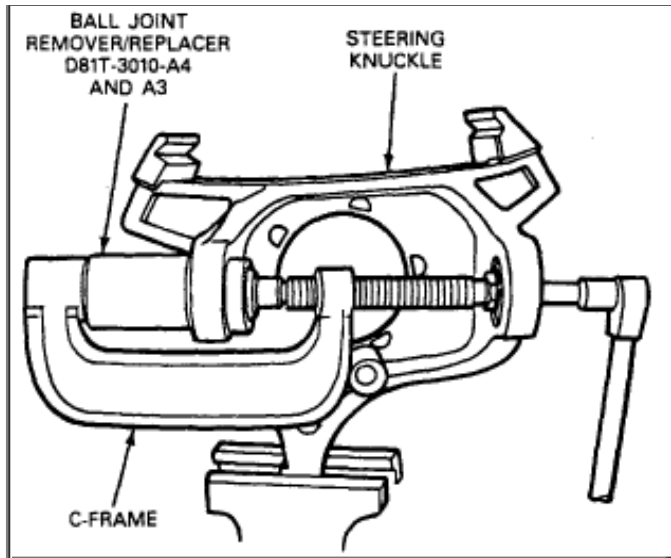

ZOOM

SIZED FOR PRINT

7. Assemble U-Joint Tool T74P-4635-C and Ball Joint Remover/Replacer T92T-3010-A over the lower ball joint. Turn the forcing screw to remove the ball joint.
8. Assemble U-Joint Tool T74P-4635-C, Ball Joint Remover/Replacer D81T-3010-A4 and Ball Joint Remover/Replacer D81T-3010-A3 or equivalents over the upper ball joint. Turn the forcing screw clockwise to remove the upper ball joint.

INSTALL

NOTE: The upper ball joint must be installed first.

1. Position the upper ball joint along with U-Joint Tool T74P-4635-C, Receiver Cup D81T-3010-A5, Ball Joint Remover/Replacer tools D81T-3010-A1, D81T-3010-A3 and D81T-3010-A4 or equivalents on the knuckle. Turn the forcing screw clockwise until the ball joint bottoms in the bore. Remove the tools.
2. Position the lower ball joint and U-Joint Tool T74P-4635-C, Ball Joint Remover/Replacer T92T-3010-B and Ball Joint Remover/Replacer T92T-3010-A on the knuckle. Turn the forcing screw clockwise until the ball joint bottoms in the bore. Remove the tools.
3. Install the snap ring on the lower ball joint.
4. Install knuckle onto tube and yoke assembly, then install camber adjusting bushing with arrow pointing outward for positive camber or towards center of vehicle for negative camber.
5. Install new lower ball joint nut and torque to **Specifications** . [See: Specifications\Ball Joint, Lower](#)
6. Install new upper ball joint nut and torque to **Specifications** . [See: Specifications\Ball Joint, Lower](#)
7. Advance upper ball joint nut to next castellation, and install new cotter pin.
8. Install brake rotor, axle shaft and [spindle](#).

12/30/2008

1990 Ford Truck Bronco Full Size V8...

Copyright © 2008 ALldata LLC

[Terms of Use](#)